

Data Processing & Calibrations

SAVE
Calibration Data Enclosed

Preliminary technical description for the new
Model H11-LIN.

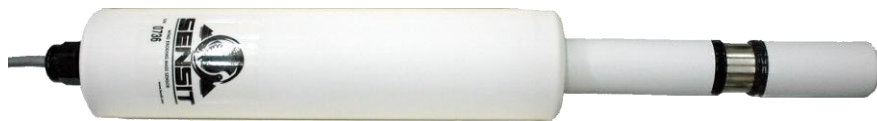

Sensit Company
939 140th AVE NE
Portland, ND 58278
<http://www.sensit.com>
email: sensit@polarcomm.com

Contents

Contents

Processing Sensit Field Data - Introduction	3
Model H11-LIN.....	3
About the new Model H11-LIN.....	3
Model H11-LIN improvements	4
Sensit PHA data requires pulse height analyzer	5
Generic PHA instrument structure	5
Sensit PHA data.....	5
Gain Selection.....	6
Model H11-LIN Wiring Color Code.....	7
Excellent Sand Catchers.....	9
The BSNE catcher	9
The Cox Sand Catcher	9
Response.....	12
Threshold velocity	12
Background.....	14
Drop Tube Test Results (Early calibration method)	14
New Model H11-LIN Radial Symmetry Lab Test.....	15
Sensor – Theory of operation.....	20
Instrument Calibration Constants (Lab & Field)	21
Laboratory Drop Tube Cal.....	22
Field Cal (Simplified).....	22
Simplified field data processing.....	25
Examples of Cal Method	25
Particle Velocity	26
Data Processing.....	27

Processing Sensit Field Data - Introduction

The basic field saltation data site is comprised of meteorological data towers complimented by sand catchers ([Figures 1a&b.2a&b](#)), the Sensit wind eroding mass flux sensor. This paper provides a brief background and suggested methods of processing Sensit field data.

The Sensit eroding mass sensor does not need to be maintained and can operate as a solar powered remote erosion monitoring station. The data acquired provides estimates of mass flux with high-resolution detail of erosion processes.

Sand catchers should be checked daily, samples collected, weighted and collection time recorded. Catcher mass (a total mass for the event reference) is necessary as a reference for the processing of Sensit kinetic energy (KE) data collected for an erosion event. Accurate catcher collection mass, data and time are very important values.

Model H11-LIN

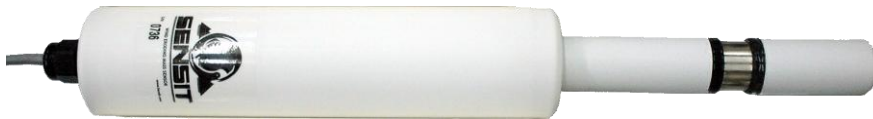

WebSite:

About the new Model H11-LIN

In addition to the same PC and KE outputs as previous Sensit models H11B & H11C sensors the H11-LIN has a PHA (pulse height analyzer) output (described below). It also has selectable gains of 1X and 10X.

It does not provide the previously seldom used outputs that were toggled versions of KE & PC. These were provided for older data loggers that did not have the ability to count pulses.

Model H11-LIN improvements

- **New data output – individual particle impact energy:** The model H11-LIN has an additional output providing the kinetic energy of every individual particle impact. This data is in the form of a variable pulse height signal. A pulse height analyzer (PHA) unit is required to capture this data and should be available by the 1st quarter 2008. The pulse is not unique in any way so it is possible there is some commercially available PHA instrument that could be used. Nuclear PHA instruments may not work because they are specifically looking for a Gaussian shaped pulse and use a peak detection circuit for their trigger. The Sensit PHA output is a square wave (a track and hold of an internal value) and the PC output is used as the PHA trigger.
- **Programmable Gain:** Sensitivity can be increased by 10X externally via data logger or by physically connecting the GAIN wire to +12V. Connected to ground or left open selects a gain of 1X. The normal sensitivity of the H11-LIN is many times more sensitive than the previous standard H11B & H11C models so the 10X feature is extremely sensitive.
- **Superior seal:** The crystal mounts now extends over the ends of the crystals providing a superior seal and protecting the edges.
- **Lower power:** The new sensor draws less current (~70ma) than the previous sensors (~90ma) in the 1X gain and a bit more in the 10X mode (~80ma). The new Sensit in any mode draws less power than previous Sensits.
- **Symmetrical response:** Uniform radial response has now been achieved by heavy nickel plating of the crystal surface. Previous Sensits had an anodized aluminum shield epoxied around the crystal for protection. Variance in the epoxy coating caused an asymmetrical response characteristic. This is no longer a problem.
- **No multiple counts:** Large energy impacts do not produce multiple counts in the PC output data. In lower end sensors this effect produces unusable data and can occur at virtually all levels of impact. Earlier Sensits did not encounter this problem until the impact energy was extreme and then rarely. This is no longer a problem at any energy level.

Sensit PHA data requires pulse height analyzer

Acquiring pulse height data requires a pulse height analyzer. The Sensit PHA output pulse may be input to any compatible pulse height analyzer for processing and collection. These units tend to be expensive and normally do not acquire a series of spectrum. Sensit plans to produce a PHA module by the 1st quarter 2008 that will process and record up to 1000 spectrum. This is a substantial amount of data but may provide invaluable information about energy partitioning throughout an erosion event. Interpretation of this new ability will be left up to researchers.

PHA Background – A pulse height analyzer (PHA) produces a graphical representation of the spectrum of pulse heights. Units of time are not applicable. The x-axis represents pulse height and the y-axis is the number of counts at that pulse height. The longer a PHA is allowed to acquire data, the greater the resolution of information. i.e., a peak will become increasingly defined.

The PHA is most commonly used in the field of nuclear scintillation. It is simply the counting and sizing of radioactive particle energy. The energy spectrum of radioactive atomic particles clearly defines a radioactive isotope by "signature" peaks. Another similar effect is the mass spectrometer data.

Generic PHA instrument structure

A pulse height analyzer is an instrument with a large number of counters. The number of counters is typically 128 to 4095. Each counter is assigned to a small pulse height (voltage) range. Each counter is typically capable of counting 2^{16} -> 2^{20} counts per channel (counter). Example: If the PHA input full scale voltage range for incoming pulse heights is 4.095 Volts, and there are 4095 counters, a separate counter is assigned to count pulse heights over every 1mV portion of the 4.095 Volt range.

Sensit PHA data

The amplitude of each Sensit PHA output pulse is proportional to the energy transferred from one particle impact. It is anticipated this module will acquire up to 1000 sequential energy spectrum.

Sensit expects to have a PHA module available 3rd quarter 2008. Alternatively, if your facility is technically inclined, you could build your own pulse height analyzer. The standard Sensit PC output pulse can be used as a "sync" pulse (negative slope trigger) for your PHA. All you need to do is to do an A/D conversion of the Sensit PHA output (0->4.095 Volts) within 40uS after the falling edge of the PC output. You're A/D resolution (8, 10, 20 bit A/D) determines the number of

counters your memory must support. Use this A/D value to address a memory location where you read the value in that address, add one to it, and put it back. That's all there is to it, except for dumping the memory via RS232, USB or whatever into your computer. They are really quite simply in their elementary form.

Gain Selection

Sensitivity can be increased by 10X externally via data logger or by physically connecting the GAIN wire to +12V. Connected to ground or left open selects a gain of 1X. The dynamic range of the pulse height output covers fine to medium particle impact energies encountered during typical erosion events. The total dynamic range (10^5) of all possible eroding particle energies is too great to be covered by a single linear A/D system so we incorporated the selectable gain (X1, X10) to increase the PHA range capability.

Model H11-LIN eroding mass sensor

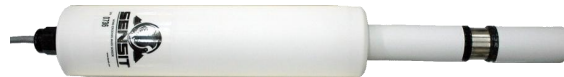

- Base diameter: 2.050", length: 8.00" +/- 0.250"
- Upper post diameter: 1.050" length: 5.50" +/- 0.50"
- Crystal diameter: 0.915" length: 0.475" +/- 0.20"
- Top of base to center of crystal: length: 3.100" +/- 0.050
- Cable diameter: 0.210" length: 25 feet.

Outputs:

- **Particle count (PC)** data output is a CMOS/TTL compatible pulse indicating one particle impact,
- **Kinetic energy (KE)** is a CMOS/TTL compatible pulse representing a fixed amount of energy that has impacted the sensor. Each pulse is always represents the same amount of total energy and is calibrated by normalizing it to the mass caught by a field catcher. The terms mass and energy are used synonymously only because empirical field data from several independent source exhibit a R^2 correlation of 0.997 between the sensor response (which is kinetic energy) and the use of this term as mass flux. The reasons for this anomaly are unknown. A lab calibration has virtually no values because there is extreme variance due to mean particle density, spin and modulus of rupture for the surface a aggregate behavior. The catcher mass normalization method compensates for a multitude of variables including day to day environmental effects of rain, humidity, radiation etc.

- **NEW: Pulse height analysis (PHA)** output is a pulse varying in amplitude with individual particle impacting energy. Pulse width: ~50uS, amplitude: 0 -> 4.8V. When input to a pulse height analyzer the PC output can be used as the sync if required. Due to the extensive amount of data, this data will be output serially via RS232 or USB.

Inputs:

- **Power:** +12VDC@70ma
- **Gain select** (1X, 10X) can be selected via data logger output (open collector w/<10K pull up resistor). Gain may also be selected by connecting this wire to ground (1X) or connected to +12V (10X).

Model H11-LIN Wiring Color Code Outputs

- (brown) KE (kinetic energy / pseudo mass flux) - CMOS/TTL compatible pulse
- (white) PC (particle counts) - CMOS/TTL compatible pulse
- (blue) PHA (particle energy) - variable pulse height

Input

- (green) GAIN – Ground (1X), +12VDC(10X). For data logger control use one of the circuits shown below

Power

- (red) Power + 12VDC @ 70ma
- (black) Ground

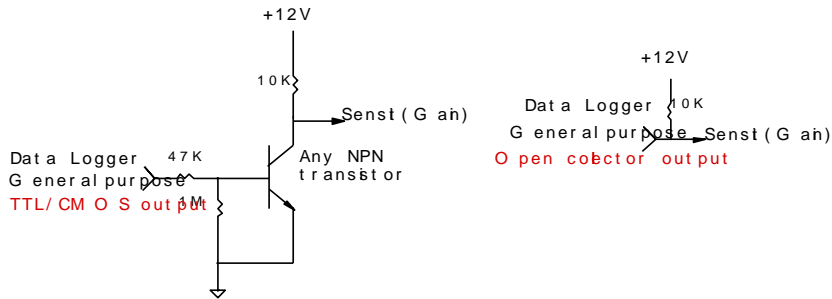

Examples of possible circuits to control gain via data logger.

Earlier models - H11B or C

(Replaced by Model H11-LIN)

Outputs

- (brown) KE (mass) - pulse
- (white) PC (particle counts) - pulse

Alternate outputs (seldom used)

- (green) KE (mass) - variable pulse width
- (blue) PC (particle counts) -variable pulse width

Power

- (red) Power + 12VDC @ 90ma
- (black) Ground

Excellent Sand Catchers

The BSNE catcher (figure 1) is designed and produced by Dr. W. Fryrear of Big Spring Texas. This catcher features the ability of attaining 100% aerodynamic efficiency. This was accomplished by a partial vacuum occurring at the back of the wedge-shaped body causing all frontal air at the frontal capture opening to enter the opening. Minimum particle diameter is determined by the rear screen size.

The Cox Sand Catcher (figure 2) is designed and produced by Bill Cox of Bishop, California. This catcher features an omni-directional capture opening with no moving parts and adjustable collection volume.

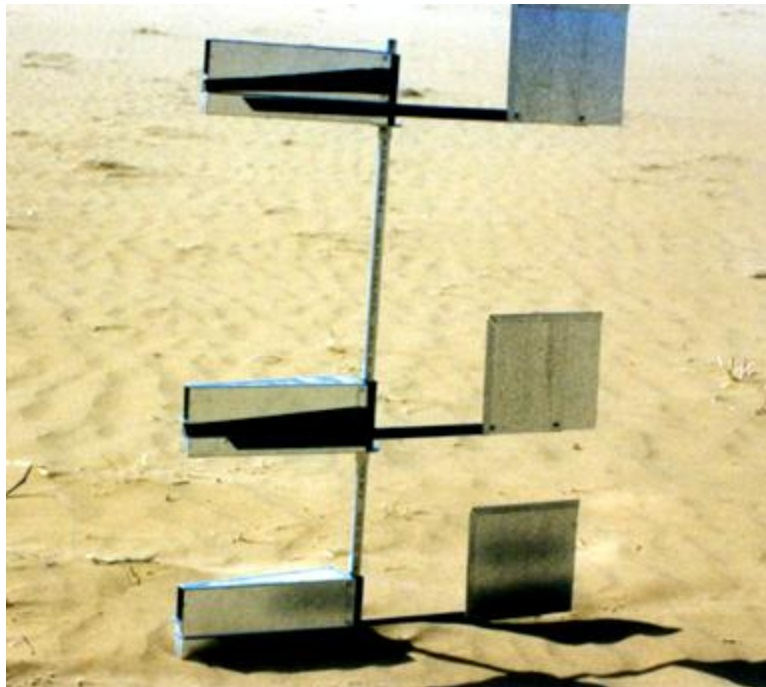

Figure 1a - USDA (BSNE) Sand Catcher

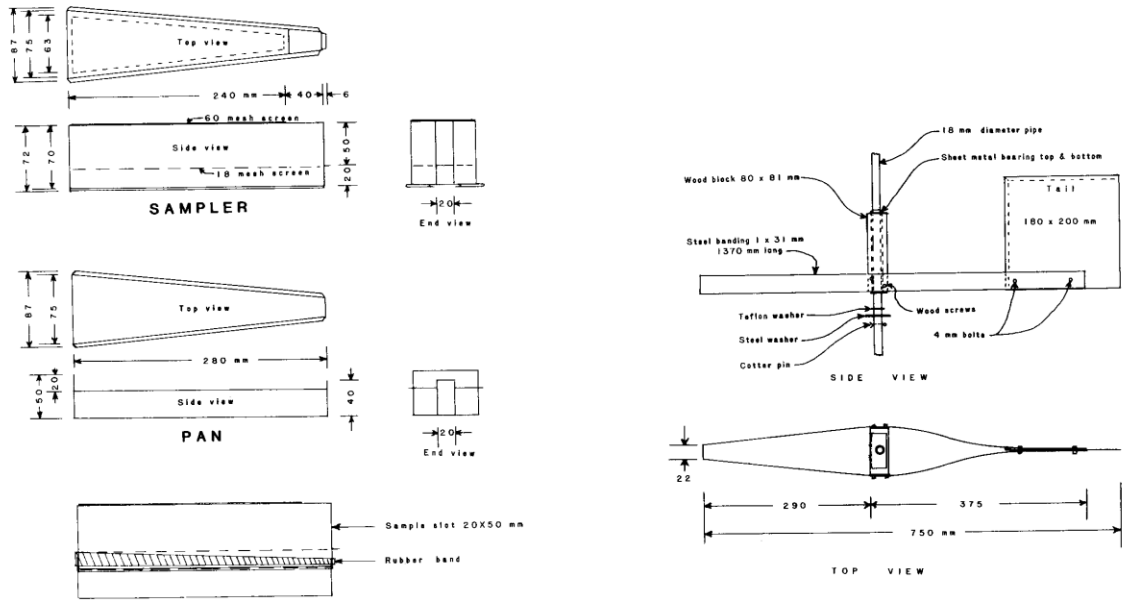

Figure 1b - USDA Sand Catcher Model BSNE

Cox Sand Catcher

10/7/1999
Not to Scale

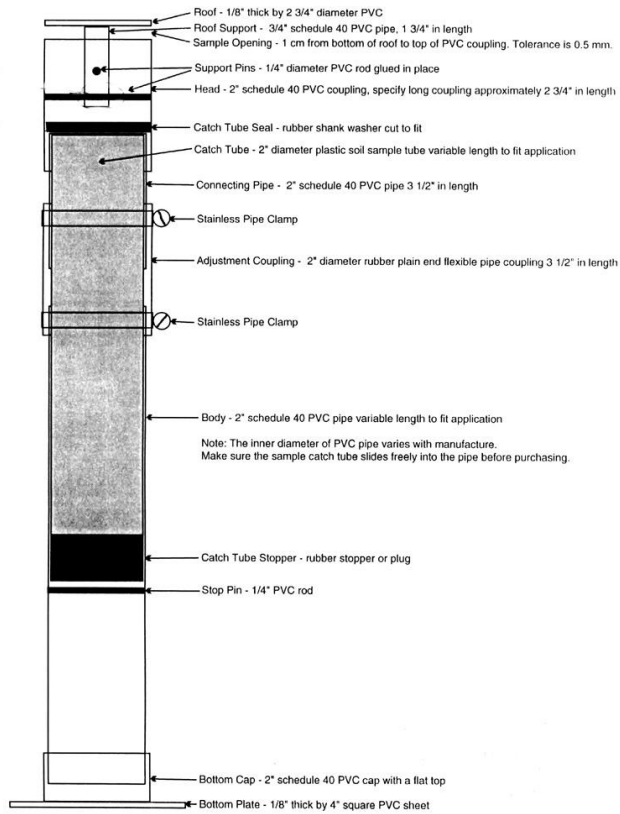

Figure 2a - Cox Sand Catcher (CSC)



Figure 2b - Cox Sand Catcher (CSC)

Response

Threshold velocity is an important term in wind erosion equations and can only be determined directly by the Sensit eroding mass flux sensor.

Prior to the advent of the Sensit, it was not possible to determine threshold velocity from field data. Threshold changes dramatically with changing soil conditions. A small amount of precipitation prior to an event or an established crust can have an extreme effect on threshold velocity. Surface characteristics during an event which effect threshold. High resolution (short sampling interval) data is necessary to observe changes in threshold throughout an event.

Figure 3 shows high-resolution Sensit data taken at Owens Dry Lake, Keeler, California. A catchers provides a reference of total mass for an event where Sensit data provides detail and threshold values.

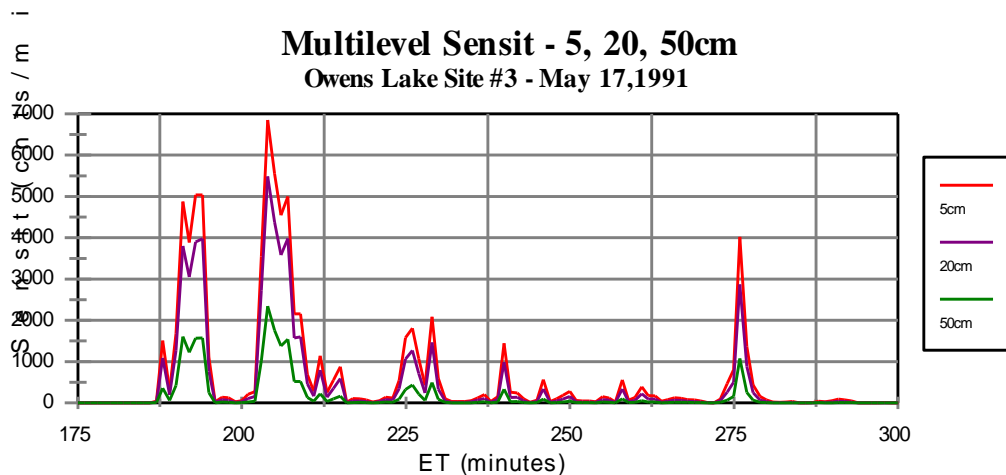

Figure 3 - Response (Sensit-5cm-20cm-50cm)

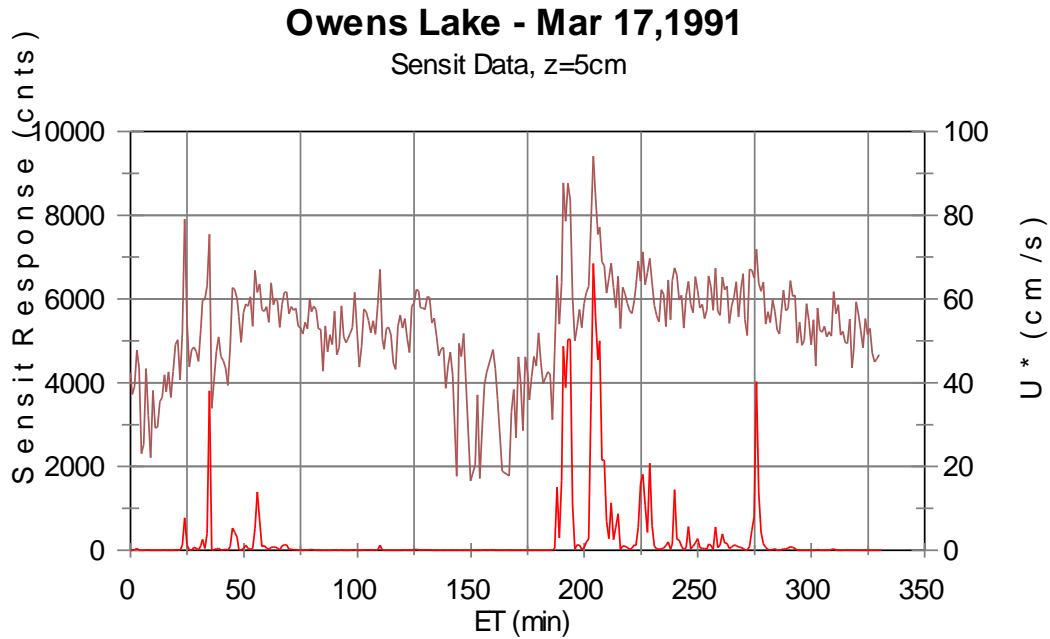

Figure 4 - Response (Sensit, U*)

Threshold velocity can be determined when the shear stress¹ of the wind (U*) is compared to the Sensits' response data as shown in Figure 4. The importance of the threshold velocity parameter is a starting point or baseline of wind erosion. Energy from saltating particles can destroy a surface which in turn makes more material available for saltation. Threshold can start out high, decrease and end up high again. Meanwhile, the wind does whatever it wants.

The Sensit does not respond to suspended fine dust². It responds to larger saltating³ particles. It is important to note that fine dust⁴ adhere to large particles vary tightly through valence bonding

¹ Shear stress (U*): Briefly, the slope of a line represents ratio of wind speed to the log of height. General equation (simplified): $U^* = 0.4 * ((u_2 - u_1) / \ln(z_2/z_1))$.

² Fine dust: Referred to here as particles of less than 75 microns in diameter which tend to stay in suspended in air with little turbulent energy.

³ Saltation: A term originally coined by Gilbert, G.K. (1914). U.S. Geological Survey, Prof. Paper 86 to describe the motion of sand under water. Derived from the Greek word saltair meaning to dance, also commonly used to describe non-suspended sand motion in air once above the surface.

Background

The Sensit wind eroding mass sensor is the successor of early instrument designed for wind tunnel basic research by Dr. Gillette, NOAA⁵ at the laboratory located at Boulder, Colorado. The original request to produce such a sensor was made by Dr. Fryrear, USDA.

The first wind tunnel instrument was a vertically oriented array of ten flat rectangular piezoelectric sensors and was used for the investigation of horizontal momentum flux [Gillette and Stockton, 1986].

Test results were encouraging after the prototype wind tunnel sensors were constructed. The USDA funded SBIR Phase I and Phase II awards making it possible to construct a laboratory drop tube test apparatus and perform several field tests. The drop tube provided control of the particle size, speed and rate. Results clearly showed excellent linearity to kinetic energy, not momentum because the transfer of energy is due to the deceleration of the particle hence v^2 .

Drop Tube Test Results (Early calibration method)

Laboratory data were collected using a *calibration apparatus* referred to as the "drop tube" to determine the sensors response and limitations. The drop tube apparatus provides a uniform source of particle impacts without aerodynamic complications found within wind tunnel profiles. It also permits the confidence of known size, shape, density and uniform particle velocity.

Field data recorded from actual erosion events was obtained by adding the Sensit instrument to operating field meteorological sites. Specially constructed multi-level kinetic energy sensors were produced to provide vertical profile information. Five sensors placed at heights of 2, 5, 10, 20 and 50cm were placed on a single one-inch diameter stainless steel mounting post.

The dynamic range of the electronics determines maximum data parameters. The minimum measurement capability is determined by the ability of the particle to impact the sensor surface by overcoming its coefficient of drag. Smaller suspended particles tend to flow around the sensor. In the drop tube tests electronic sensitivity were set high to obtain the highest possible data resolution for the very short sampling times of one second used in the tests.

⁵ NOAA: National Oceanic and Atmospheric Administration.

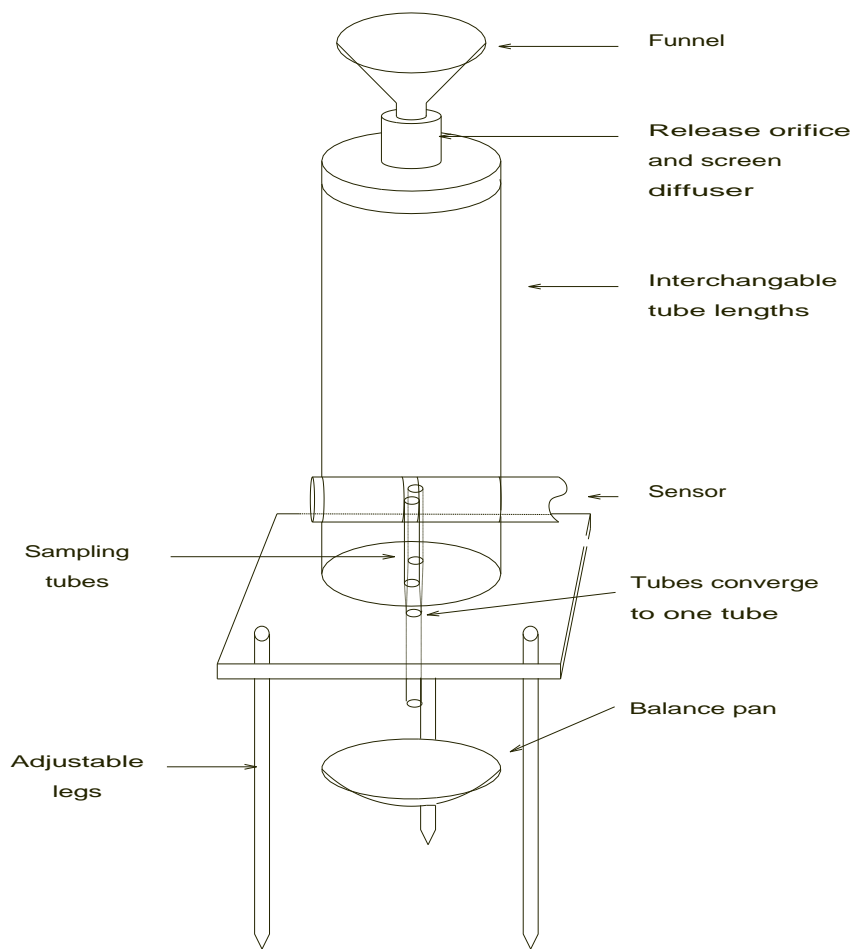

Figure 5 - Drop Tube Apparatus

New Model H11-LIN Radial Symmetry Lab Test

The Model H11-LIN now replaces all previous models. A new standard output is a 50uS wide pulse whose height varies with impacting energy. There is one variable height pulse for each particle impact. This output is referred to as the PHA (pulse height analyzer) output. The PHA output provides a new per-particle data tool permitting detailed laboratory calibrations.

The height of the pulse can be calibrated to individual particle impact energies providing an impact energy reference. Useful, but remember field data must **always** be referenced to a catcher mass to include a multitude of anomalies unique to the site samples.

The PHA output provides an analog per-impact response value that is an ideal signal to test the sensor's minimum/maximum impact energy limits and characterize the radial response pattern for symmetry.

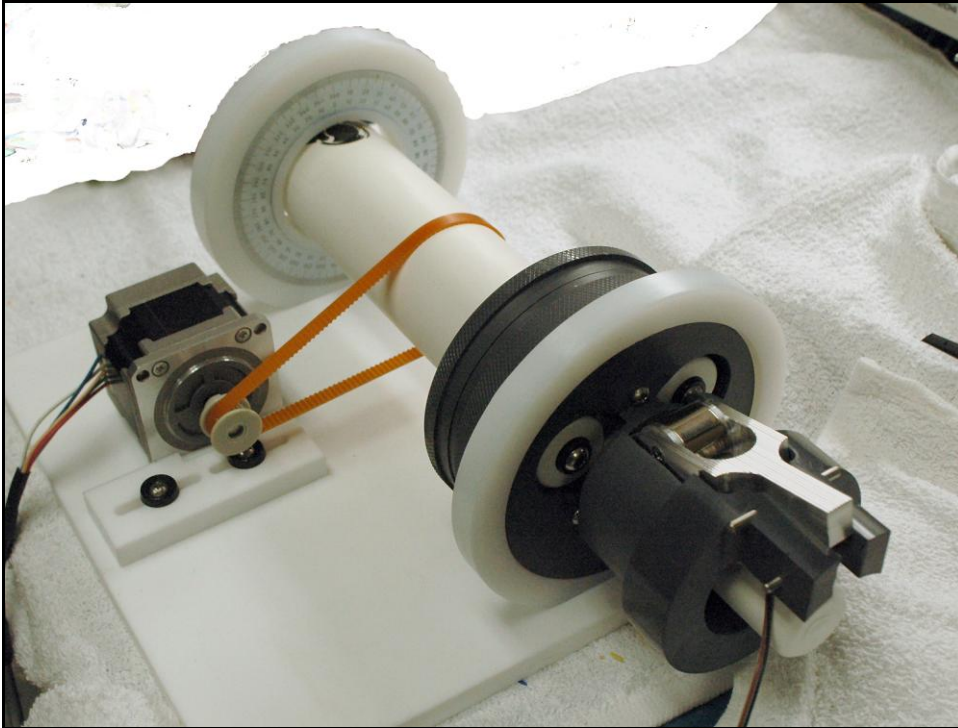

Figure 6 – Radial Symmetry Response Apparatus

Figure 6 shows the radial test apparatus. A stepper motor rotates the sensor through 360 degrees stopping at selectable intervals such as 1 or 10 degrees. During each pause, the crystal exciter (source of kinetic impact energy) impacts the sensor's crystal. The PHA output for this impact is recorded for graphical analysis as shown in Figures 7A & 7B.

As this apparatus is developed, it is expected to provide impacts of selectable calibrated energy that will be useful for establishing response threshold and maximum energies for the PHA outputs analog range.

There is no maximum impact energy the PC (particle count). But the KE (kinetic energy) data can experience saturation because internally it is derived from an analog signal.

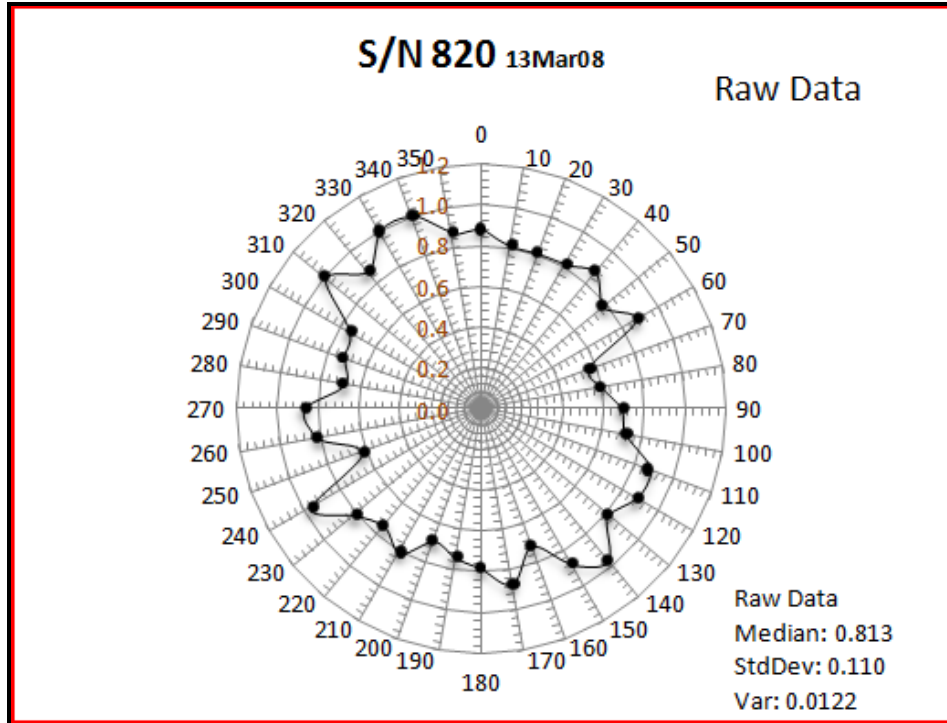

Figure 7A – Radial symmetry – raw data

Figure 7A is actual raw calibration data. The excessive variance is due to the finite point contact of the device source crystal against the sensor's nickel plated surface. Underlying the nickel plating is a thin layer of conductive paint deposited by the crystal manufacturer. This layer of paint can vary in thickness and even have drips which constitute "bumps" in the soft inner layer. Such anomalies cause extensive point measurement variance.

The sensor's active surface inherently averages the 180 degrees of frontal area even though it includes a cylindrical geometrical consistent. To provide a more meaningful representation of directional response, the 10 degrees per sample calibration data is averaged over 120 degrees (Figure B). Granted, the averaging scheme should be cosine or perhaps Gaussian weighted to be more correct but limited time has put this automated task on the back burner.

I expect further refinements under software control such as the above mentioned averaging and provision of easily controlled parameters of degrees per sample, samples per data point and control of impact energy.

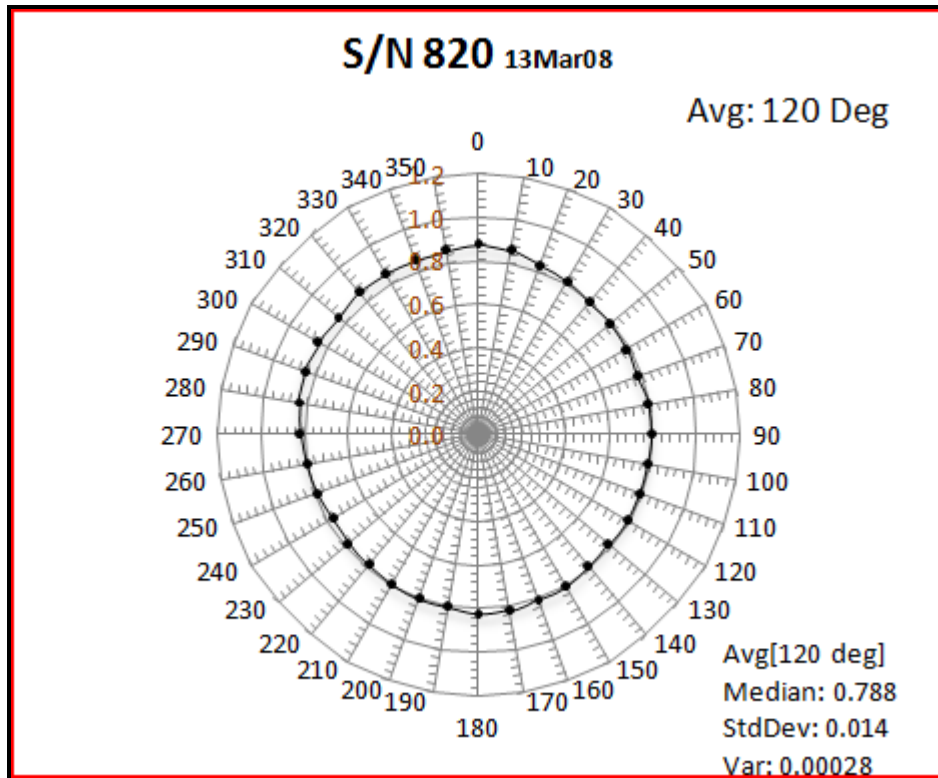

Figure 7B – Radial symmetry – averaged data [120 degrees]

Figure 7B shows the result of averaging the raw data of Figure 7A over sectors of 120 degrees. The frontal area of the sensor during saltation is approximately 180 degrees but vast majority of impacting energy is occurring over <120 degrees. This is an arbitrarily selected value.

The resulting response pattern is excellent compared to older model sensors. The symmetry response improvement was achieved by eliminating the aluminum shield that was epoxied to the crystal to protect the surface from effects of sand blasting. Unfortunately, it was not possible insure a consistent thickness of epoxy. The Model H11-LIN has no aluminum shield. The conductive electrode paint on the surface of the crystal is directly nickel plated.



Figure 8 – Radial symmetry calibration index mark

The zero degree reference in the radial response calibration of figure 7B is indicated by the index sticker on the upper part of the sensor. If the sensor is suspended upside-down over the surface of the ground the + and – direction marks on the label indicate the direction of the degrees shown in the calibration graph. If this decal should erode away, here is a little secret; when calibrating, I generally align this mark with the tip of the stem of the leaf on the large decal on the body of the sensor. So, do not twist the heat shrink! And, never remove the heat shrink because it is used to eliminate particles from impacting the metal surfaces. The crystal will pick up this "loud" impact and cause falsely produced data. The heat shrink softens impacts to a level below detection threshold.

Sensor – Theory of operation

The charge portion of the energy within the crystal can be roughly expressed as:

$$Q = C * V$$

where:

- Q charge in coulombs.
- C capacitance in farads.
- V the voltage developed across the crystal.

conversely:

$$Q = I * t$$

where:

- I current developed over time (t)

Therefore:

The charge developed is a representative portion of the energy instantaneously imparted to the crystal by the impacting particle.

The crystal is a damped harmonic oscillator, which has this basic equation of motion:

$$X(t) = e^{-(fr)t} A \cos(f_d t - \theta)$$

where:

- X(t) displacement.
- d damping resonance of crystal.
- θ phase angle.
- A constant of integration.
- fr natural resonant frequency.
- f_d damped resonant frequency

The circuit used to measure this charge integrates the area of both alternations of the complex damped waveform from every impact. When the output of the integrator reaches a predetermined voltage, the integrator is reset. This reset is stretched to become the output pulse or data produced by the instrument.

Each output pulse of the instrument represents:

$$KE = \int^t \frac{1}{2} m V_p^2 dt$$

where:

KE One kinetic energy instrument data unit.

V_p Particle velocity.

m Mass of each particle.

t Time to accumulate one data unit.

Instrument Calibration Constants (Lab & Field)

There are two calibration constants common to the sensor, the laboratory drop tube and the field calibration constant. Both are used to convert the sensor response to kinetic energy. The field calibration (method #2) constant has the capability of allowing particle velocity estimation for every data point.

The old method lab cal (drop tube) involves known measurements of mass, velocity and kinetic energy. The new radial response calibrator Figure 6 is expected to soon replace the drop tube apparatus for static impacting energy calibrations.

The **field cal** makes use of known mass, kinetic energy and a particle velocity term proportional to the driving force of the wind (U^*).

Laboratory Drop Tube Cal

The **laboratory cal** (K_L) is accomplished using the drop tube apparatus previously described. The lab cal converts the sensor response (KE) to units of kinetic energy using a known mass (m) and known particle velocity (V_p) satisfying the kinetic energy equation.

$$K_L = m / 2 \sum [KE / V_p^2]$$

where:

m catcher mass

KE Sensit raw response per sampling period

V_p particle velocity

Field Cal (Simplified)

The **simplified field cal** (K_F) relates the total sensor response to total mass allowing the Sensit to provide a representation of estimated mass flux. Most Sensit users prefer this simple relationship because empirical tests conducted by the United States Department of Agriculture (figure 9a), Great Basin Air Pollution Control District (figure 9b) and others consistently demonstrate a linear relationship between Sensit response to catcher mass. The field cal (K_F) assumes the Sensit response is proportional to saltating mass flux for active area and height of the sensor.

SENSIT (mass) vs WEIGHING SAMPLER (mass)
Dust Storm - Big Spring Texas 3/23/87

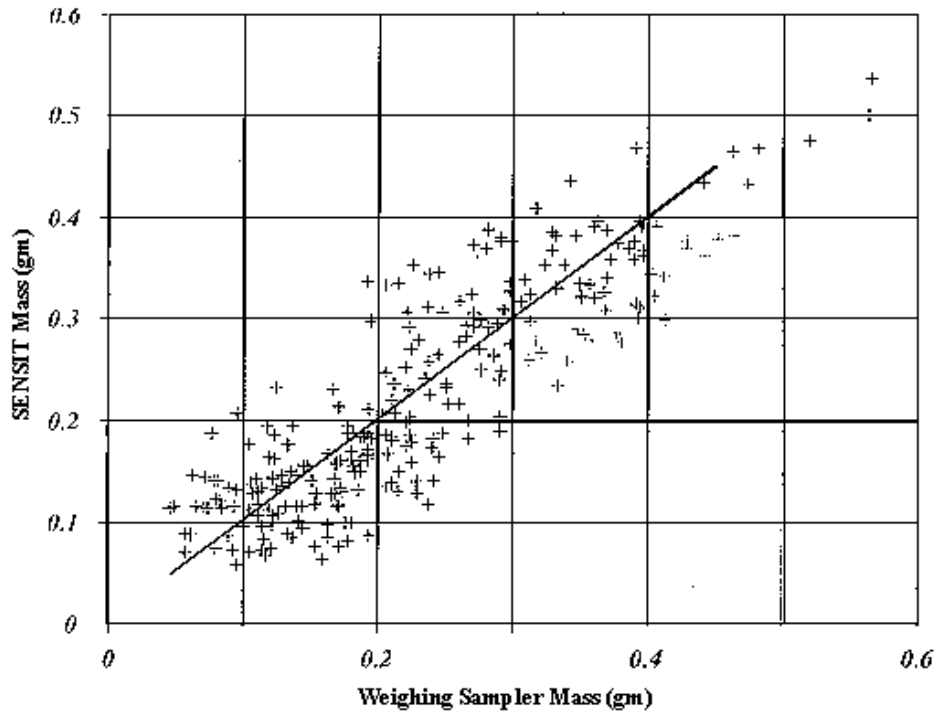

Figure 9a – Sensit vs Weighing Catcher Mass

Figure 9b displays the linear relationship of several Sensit responses vs. the mass caught by the Cox Sand Catcher (CSC, figure 9b). Figure 9c displays good correlation between the BSNE and Cox Sand Catchers.

Relating kinetic energy measurement of the Sensit to mass flux has been empirically shown to have viable linearity. A great deal of thought by many researchers has been put to identifying the underlying causes for this relationship but remains a mystery of the erosion process to date. Since saltation is driven by energy mass flux should relate well to an energy measurement, yet many details of this process remain unexplained.

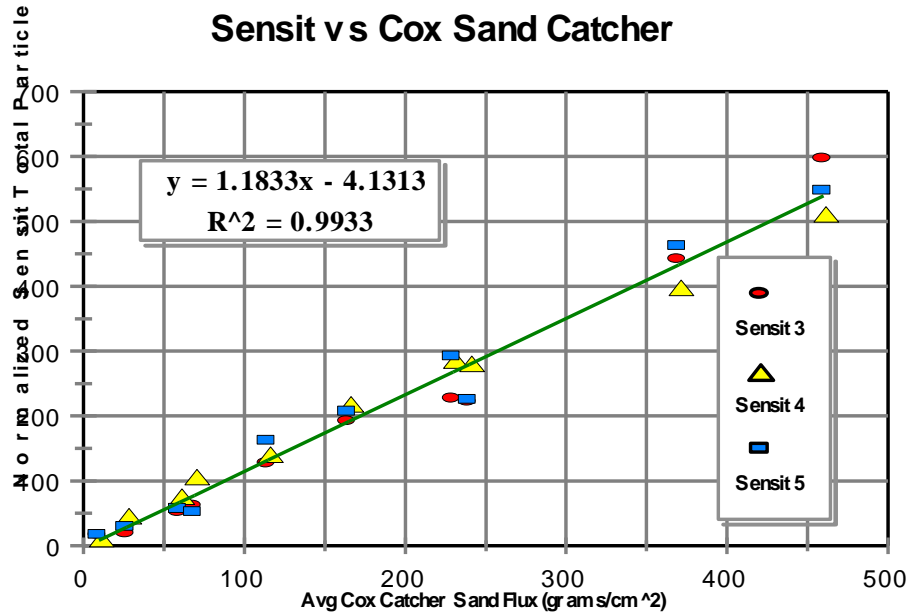

Figure 9b – Sensit Response vs Cox Sand Catcher⁶

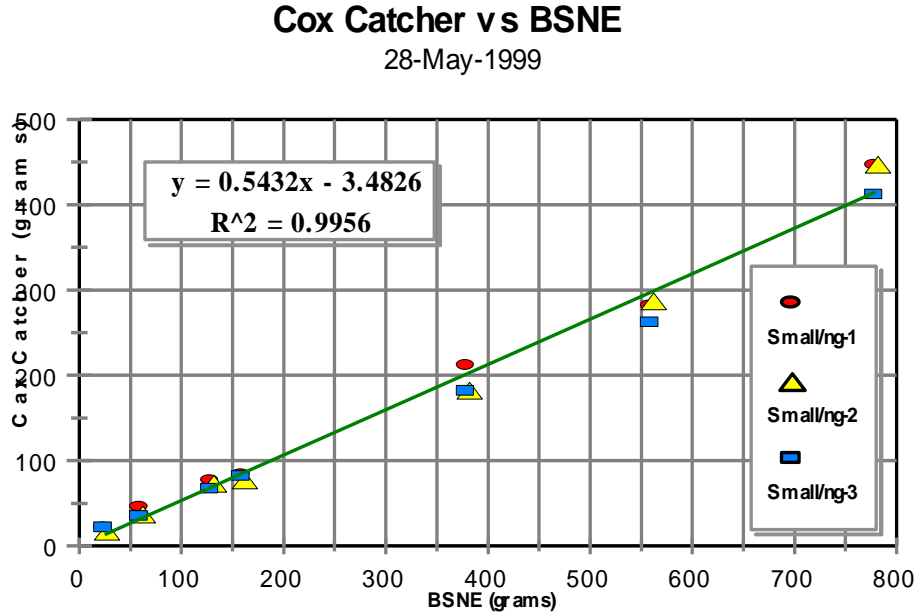

Figure 9c – Cox Sand Catcher vs BSNE

⁶ Figures 9b and 9c data courtesy of Great Basin Air Pollution Control District, CA.

Simplified field data processing

$$K_F = m / \sum [KE]$$

where: m Catcher mass

KE Sensit raw response per sampling period

Process Sensit data to estimate mass flux per data point as:

$$m' = K_F KE \text{ (per data point)}$$

Examples of Cal Method

Method #1 Field Cal

Site #3 - 5cm - May 17, 1991

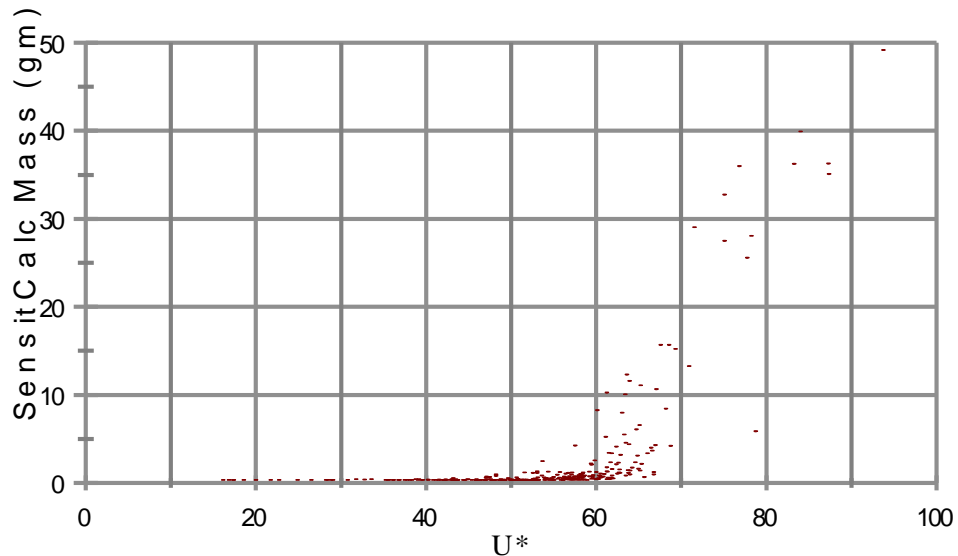

Figure 10 – Example of processed data

A comparison of processed data is shown in figure 10. Both are the same data set of Sensit response.

Particle Velocity

(Note: Processing of field data for particle velocity may require complex iterative programming techniques.) This is very difficult to process successfully. After determining the field cal incorporating U^* as a term proportional to velocity, we can now estimate the velocity of the saltating particles (V_p).

$$V_p = \sqrt{(K_F m' / 2 KE)}$$

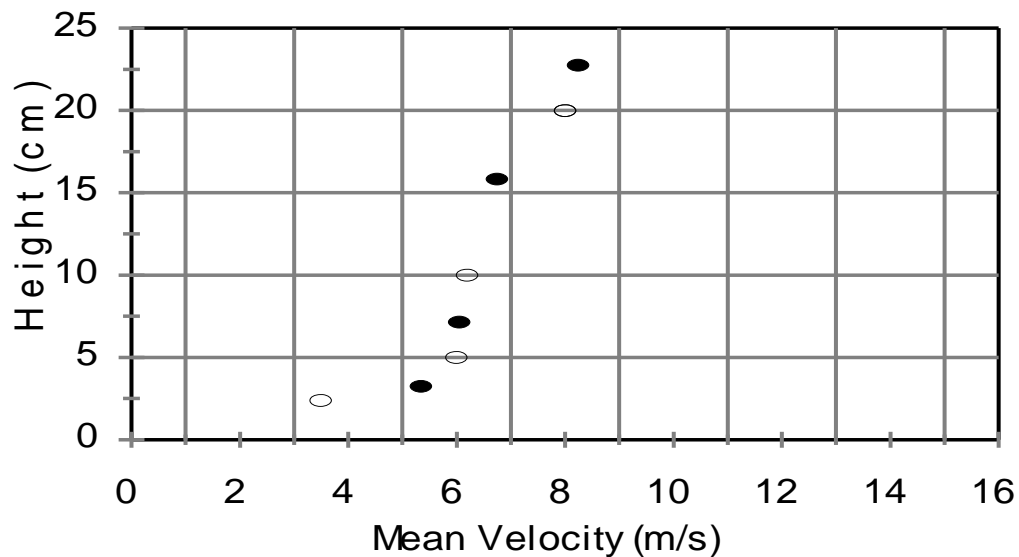

Figure 11 – Particle Velocity (Brooking, 1983)

Figure 11 is the combined data of the Sensit calculated particle velocity and wind tunnel velocity data (Brookfield, Guelph, Canada, 1983). The Brookfield data (solid dots) mean particle diameter is 350 microns. The Sensit data (circles) is actually erosion data taken at Big Spring, Texas on Mar 4--8, 1991.

Particle Velocity

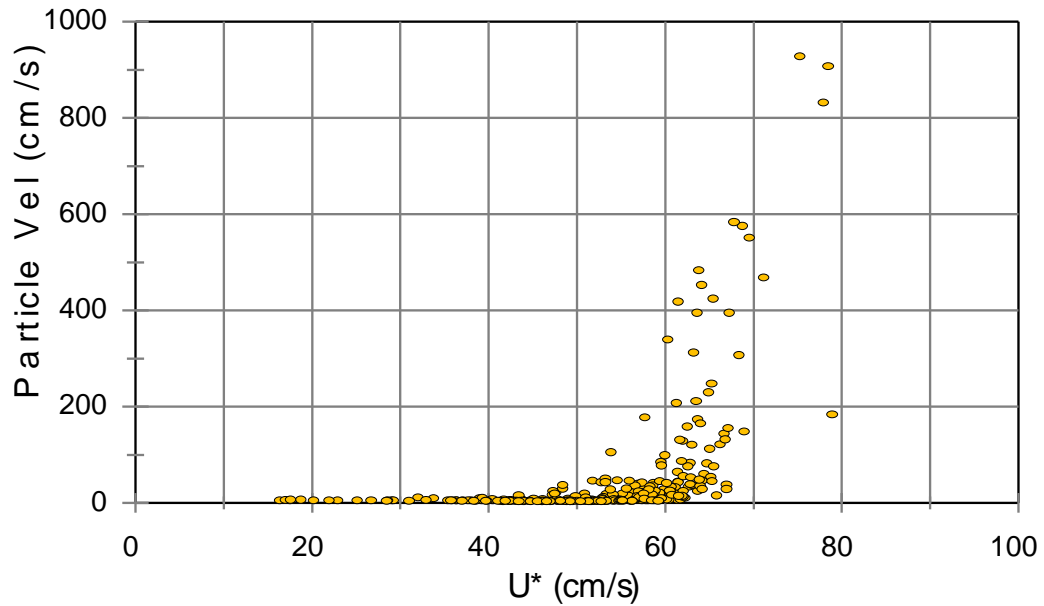

Figure 12 – Sensit Particle Velocity Data

Figure 12 shows indicates the relationship between U* and Sensit calculated particle velocity.

Note; it is very difficult to process velocity data.

Data Processing

For each data point, U* is calculated as:

$$U^* = k \frac{U_2 - U_1}{\ln(Z_2 / Z_1)}$$

where :

- U₁, U₂ wind speed at heights Z.
- K von Karman constant = 0.4
- Z₁, Z₂ anemometer heights

alternately:

$$\frac{U}{U^*} = \frac{1}{k} \ln \left[\frac{z}{z_0} \right]$$

where:

U wind speed at heights Z
Z₀ aerodynamic roughness height

Remember, many simply use the KE output without accounting for U* in the process. It turns out very good linearity has been reported by several independent investigators between the raw KE data and mass flux. The only way this can happen is if the velocity term of KE remains fairly constant. And, I believe this is true via a self-governing effect between available downward momentum and the energy lost to moving particles. I do not know of any published research to this effect. The equipment to perform such a study is here and available, so please, someone work on it.

We hope this paper is of some help with understanding Sensit data and the use of this sensor to provide quality erosion data for your project. The design of this sensor is entirely the result of valuable feedback from users like you. All comments are welcome.

Please inquire to: sensit@ipolarcomm.com

Figure 13A & B – Electrical Hookup Wiring Code

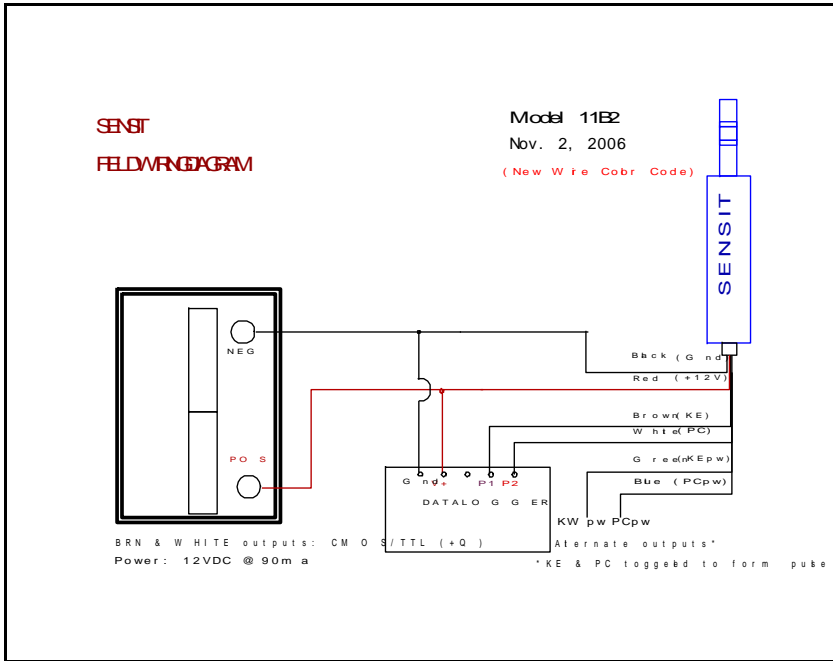

Model H11B wiring color code.

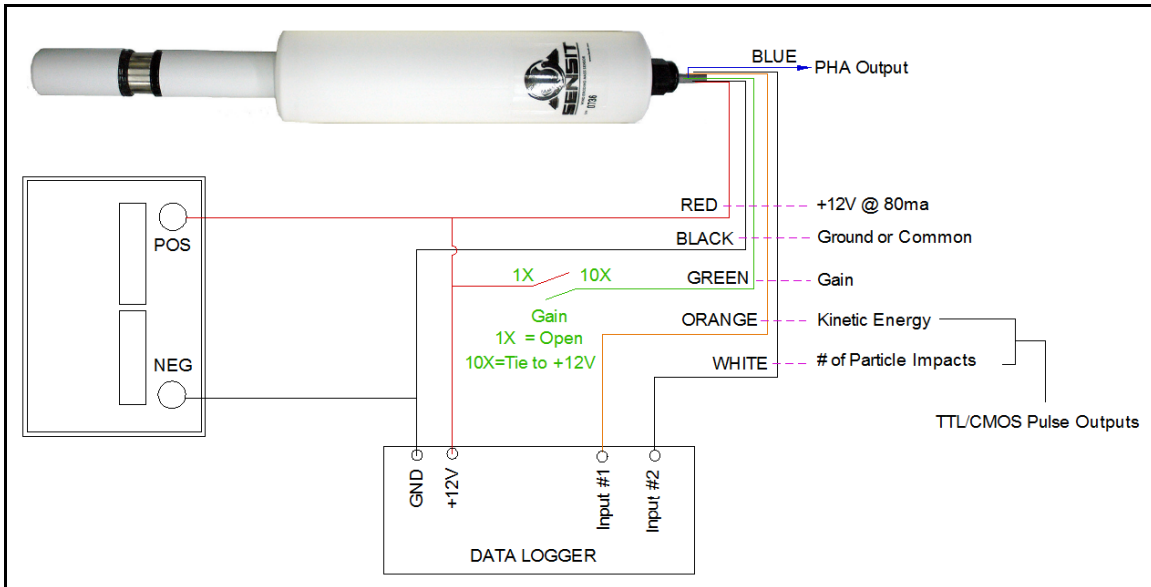

Model H11-LIN wiring color code.



Model H11-LIN
Introduced
June 2007

